



BHAI PARMANAND VIDYA MANDIR

ज्ञानाय दानाय च रक्षणाय

Pre Primary Holiday Homework 2026-27





Holidays are the precious time for children to relax, explore, and grow through new experiences. They offer opportunities to learn beyond the classroom, nurture curiosity, and engage in joyful discovery at their own pace. When guided meaningfully, holidays can become a wonderful blend of recreation and learning, helping children strengthen concepts, develop skills, and cultivate creativity in a natural and enjoyable way.

With this thought in mind, this Holiday Homework has been meticulously crafted to provide a harmonious blend of playful exploration, guided practice, and concept reinforcement, ensuring a joyful yet productive learning experience during the holidays.



Wonderful Ears at Work

Listening is a foundational skill that helps children follow instructions, strengthen memory, and respond thoughtfully. To nurture these skills through playful learning, children can enjoy activities such as Colour Hunt – “Find 3 things in our home that are blue,” Shape Hunt – “Can you find a circle in the kitchen? A rectangle in your room” and Letter Hunt – “Find something that starts with B.” Through these fun listening-and-search challenges, children learn to observe carefully, think actively and connect learning with their everyday surroundings.



Reading Readiness

Reading is an important skill to develop at an early age, it needs regular exercise to grow stronger. Build your child's reading skills at home. Make reading an interactive activity. Read books every day and let your child predict the ending or tell the best part of the story. Give them newspaper cutting and tell them to highlight sight words like *I, he, she, my and it.*





Suggested Stories

- The Panchtantra Stories
- The Hungry Caterpillar
- The Monkey Puzzle
- The Smartest Giant in the Town



Suggested TV Channels/ Movies

- The Jungle Book
- Stuart Little
- Toy Story
- Spy Kids

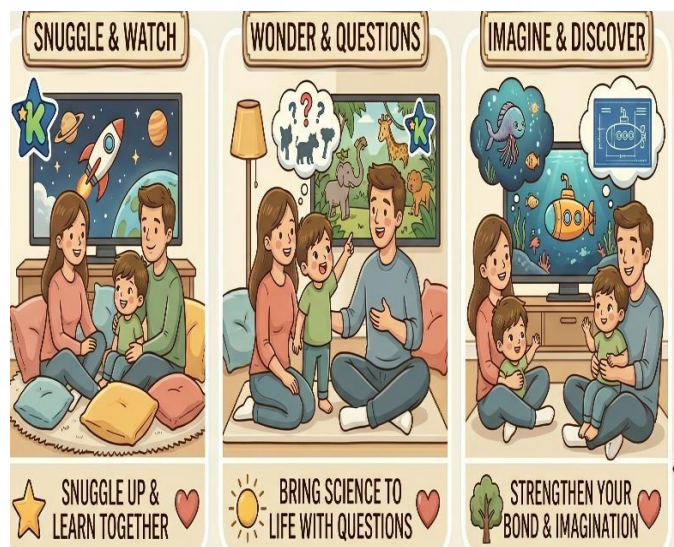



Speak up Sprouts!



Nurture your child's English speaking by using simple sentences in everyday conversations at home. Practice sentences such as:

- May I quench my thirst?
- May I have my lunch/fruit?
- I am not feeling well.
- Please Give me a pencil.
- May I borrow your sharpener?



➤ Similarly, children can be encouraged to use simple words and sentences at home too, like:

- Mumma, please give me something to eat.
- May I have a glass of water please?
- I am feeling sleepy.
- I am hungry/famished.
- May I watch Television?
- My stomach is aching.



Tiny Hearts, Mighty Minds

- Encourage your child to trim nails on regular basis, Wash hands frequently, Wish and welcome guests, spending time with grandparents/cousins etc.



Help your precious one to be independent by motivating them to:





English in Action

Word Fun

This is a fun learning activity, where kids can learn words very easily.

Activity:

A sand/salt tray is another great tool to use to learn words. The feel of the rough sand or salt helps kinesthetic learners memorize the words.

Things required:

- Some sand/salt or semolina
- Empty Tray

Directions:

Take a bowl of some sand/salt/ semolina.

Spread the sand/salt/ semolina into the empty tray.

- Use index finger, trace the words on the tray as shown in the picture.
- Encourage him/her to speak all the sight words and Group1 Words taught in the class, while tracing them.

Words:

- ❖ at
- ❖ it
- ❖ sit
- ❖ sat
- ❖ pit
- ❖ pat
- ❖ tip
- ❖ tap
- ❖ nip
- ❖ nap
- ❖ ant
- ❖ tin





Math Adventures



Activities

Hopscotch Game :

Write down numbers on the floor and ask your child to first identify and then hop to the number you will say. For example, when you will say, "Hop to the number that comes before 5," your child has to identify that the number is 4 and then hop towards the number.



Number Line Race:

Create a number line with the set of ten numbers like. 1 to 10, 10 to 20 on the floor using tape or chalk.

Child takes turns rolling 2 dice and moving that many spaces.

To practice "before" and "after", ask child what number they were on before their turn and what number they will be on after their turn.





Spot the Numbers

Create flash cards with numbers 1 to 51.

Shuffle the cards and place them face down.

Players take turns drawing a card and saying the number that comes before and after the drawn number.

For example, if the player draws 30, they should say 29 and 31. If the player answers correctly, they keep the card.

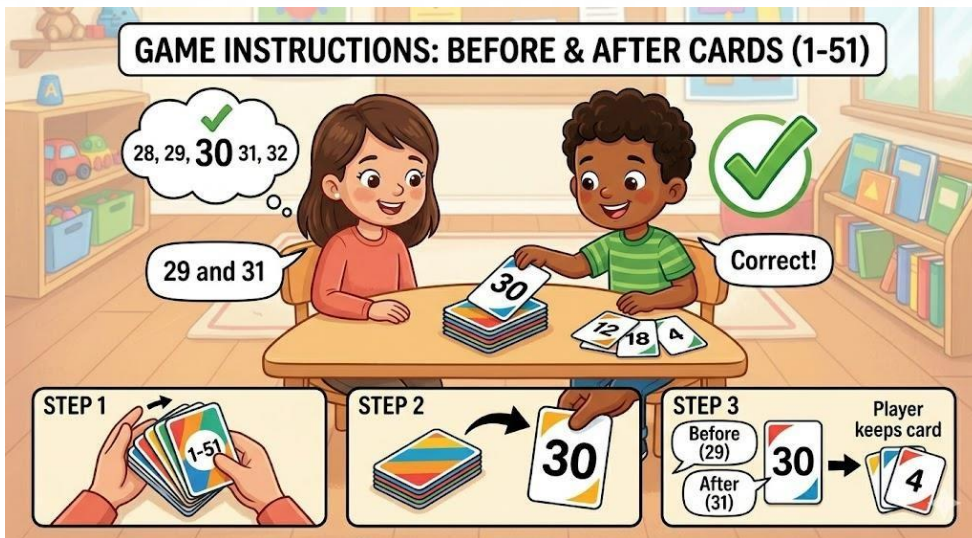

Number Neighbours Activity

Help your child understand how adding one gives the next number and taking away one gives the previous number through this hands-on practice.

Take two bowls. Put 30-35 kidney beans in one bowl. Transfer 5 beans to the second bowl and count them. Now, add one more bean to 5 to show that it becomes 6 (number after). Then, take away one bean from 5 to show that it becomes 4 (number before). Repeat with different numbers.

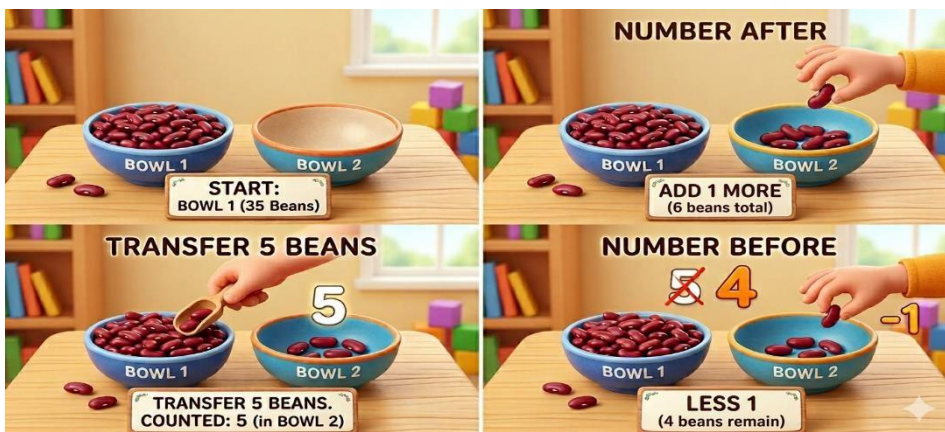



Little Life Explorers



Through *Little Life Explorers*, children will joyfully discover the world around them while nurturing their physical, emotional, and overall well-being. They will engage in simple, meaningful activities that connect them with nature, helping them stay active, express their feelings, and develop care and respect for the environment. This journey encourages young learners to grow into mindful, happy, and healthy individuals.

Nature Walk:

Take your child for a pleasant garden walk in a nearby park or garden. Encourage them to observe flowers, birds, and the fresh surroundings, and talk about what they see and feel. This simple activity helps children stay active, feel calm and happy, and develop a loving connection with nature.



My Mini Garden:

Help your child start a small garden at home by sowing a few seeds in pots or soil. Encourage them to water the plants regularly and observe how they grow each day. This activity helps children understand the process of growth, builds a sense of responsibility, and nurtures care and love for nature.





Helping at Home:

Encourage your child to take part in simple daily tasks like arranging shoes in the rack, folding clothes, or helping to lay the dinner table. These small responsibilities build independence, develop good habits, and instill a sense of care and contribution towards their home.



Little chef at Work:

Help your child to prepare lemonade or a simple salad at home. Encourage them to measure, mix, and arrange the ingredients with your guidance. This activity helps children understand basic measurements, builds independence, and makes learning fun through experience.





Tiny Yogis, Big Energy



Encourage your child to practice a few simple yoga poses daily in a calm and comfortable space. Guide them to stretch gently, breathe deeply, and relax their body and mind. This activity helps improve flexibility, builds focus, and promotes a sense of calmness and overall well-being.



Happy Father's Day

A father is like a strong pillar who protects us, guides us, and encourages us to do our best. He fills our lives with warmth and happiness.

Let's make these fun Father's Day portrait toasts for our fathers as a lovely way to show love and gratitude.



Basic Ingredients

- Bread slices (white or brown)
- Butter / cream cheese / mayonnaise (for spreading)
- Cheese slices (optional, for smooth base)

For Decoration (as seen in the image)

- Cucumber slices (eyes, cheeks)
- Black olives (eyes, eyebrows, pupils)
- Carrot sticks/slices (nose, hair)
- Capsicum (green/red) (glasses, lips, bow tie)
- Cauliflower florets (beard)
- Fresh coriander leaves (hair)
- Tomato pieces (mouth)
- Optional: boiled corn (for eye centers)



- 
- 
- Bread slices (white or brown)
 - Butter / cream cheese / mayonnaise (for spreading)
 - Cheese slices (optional, for smooth base)

Step-by-Step Recipe

1. **Toast the Bread**

Lightly toast the bread slices until golden.

2. **Spread the Base**

Apply butter, cream cheese, or mayonnaise evenly.

(You can also place a cheese slice and let it soften slightly.)

3. **Create the Faces**

Now comes the fun part—arrange veggies to make different expressions:



- **Eyes:** Use cucumber slices + olive rings
- **Nose:** Small carrot piece
- **Mouth:** Tomato or capsicum slice
- **Hair:** Coriander leaves or carrot sticks
- **Beard:** Cauliflower florets
- **Glasses:** Thin capsicum rings

4. **Get Creative**

Make different "portraits" — funny, serious, surprised—just like in the picture.

5. **Serve Fresh**

Best enjoyed immediately so the toast stays crisp.



Smile And Solve !

Let's make learning fun for our kids! Engaging in playful worksheets and activities is not only enjoyable but also crucial for their development. It helps build problem-solving skills, creativity, and confidence. Encourage your child to participate in these interactive exercises, and watch them thrive! Ask them to give it a try and have fun while learn



Smile And Solve !

Let's make learning fun for our kids! Engaging in playful worksheets and activities is not only enjoyable but also crucial for their development. It helps build problem-solving skills, creativity, and confidence. Encourage your child to participate in these interactive exercises, and watch them thrive! Ask them to give it a try and have fun while learning!"



Name: _____

Sight Words: Colorful Leaves

Directions: Use the color code to color the leaves.

I = 

my = 

she = 

he = 

it = 











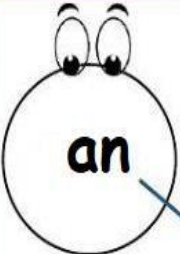

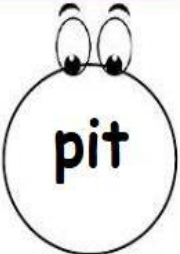
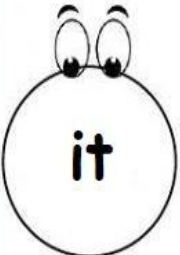
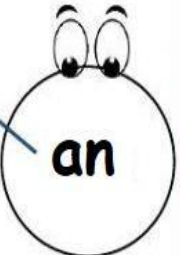



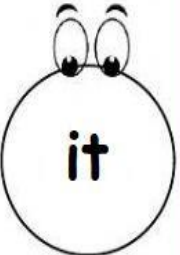



Read and Match.

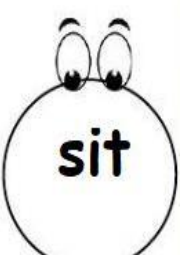

Read out the words and then draw a line to connect to the matching words.

 an	 in	 pat	 pit
 it	 an	 pit	 nip
 at	 it	 sit	 pat
 in	 sat	 pan	 sit
 sat	 at	 nip	 pan

CRACK THE CODE!

Name: _____

CODING

Decode and write down the encoded words.

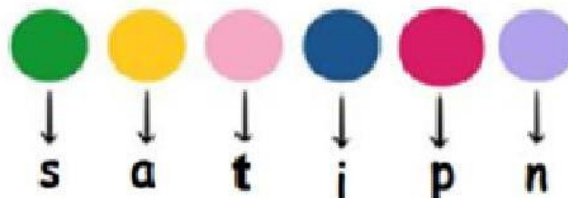

	Yellow	Pink			a	t
Purple	Yellow	Red				
Red	Blue	Purple				
Red	Yellow	Pink				
Yellow	Purple	Pink				
Pink	Yellow	Purple				
Purple	Yellow	Red				
Green	Yellow	Pink				
Green	Blue	Red				

Phonics

Sounding and counting is fun!



READ the words,  the sounds then select the number of sounds you hear. 

ant



3

at

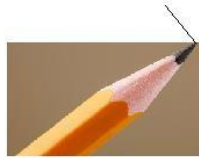

3

tip

2

it



3

tap

3

in

2

tin



2

an

3

nip



2

pat



3

Segmenting Sounds

Each word has two or three sounds. Colour the box **und** according to the given instructions.



tip

Colour the box for the first sound in picture name/word.

--	--	--



tin

Colour the box for the third sound in picture name/word.

--	--	--



sat

Colour the box for the second sound in picture name/word.

--	--	--



tap

Colour the box for the third sound in picture name/word.

--	--	--



sip

Colour the box for the second sound in picture name/word.

--	--	--



nap

Colour the box for the first sound in picture name/word.

--	--	--

Phoneme Segmentation

Instructions:

Say the words of the picture below. Colour the correct number of dots for the sounds that you hear.



pan

○	○	○	○
---	---	---	---



pit

○	○	○	○
---	---	---	---



pat

○	○	○	○
---	---	---	---



ant

○	○	○	○
---	---	---	---



nip

○	○	○	○
---	---	---	---



sit

○	○	○	○
---	---	---	---

Order the words correctly.

1 

a	n	p

2 

t	n	i

3 

a	p	n

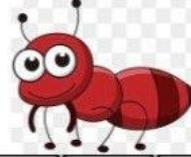
4 

n	a	t

5 

i	p	n

6 

t	p	a

Look at the picture and write the word.



Listen to the word and circle the correct spelling.



sat

sut

set



pit

pat

pet



nep

nap

nip



pat

pit

put



pin







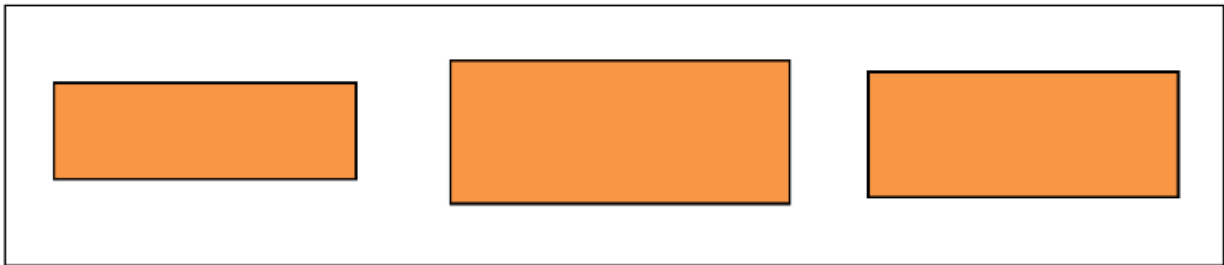
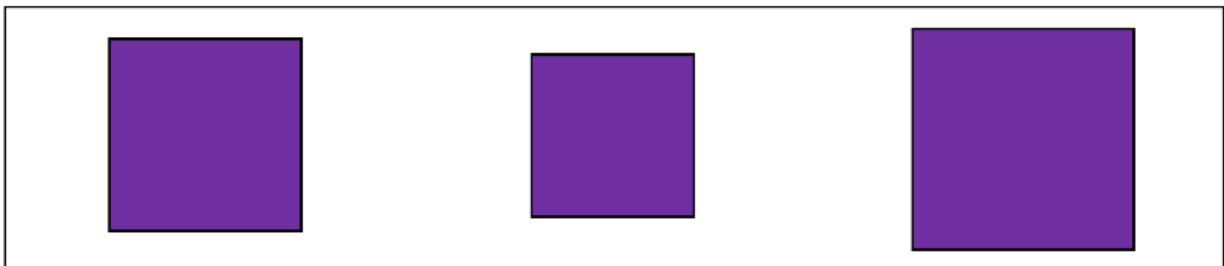
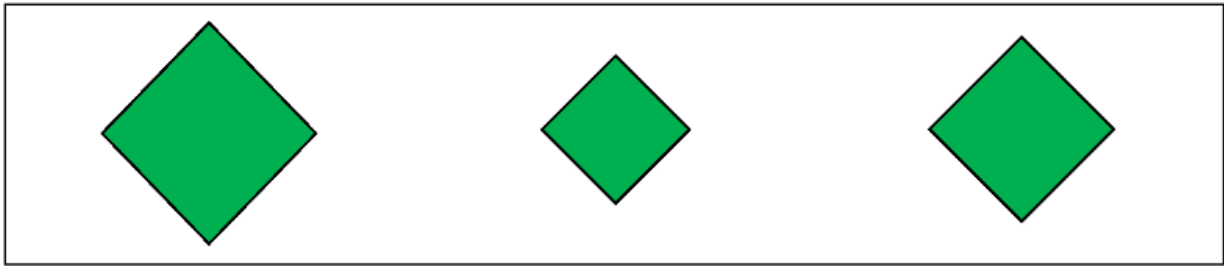
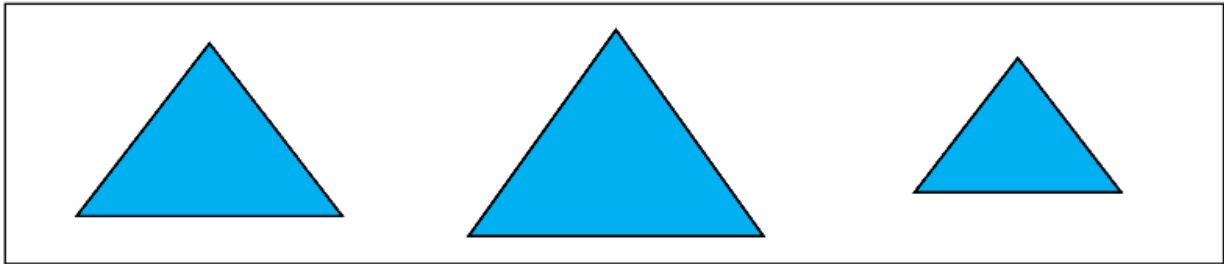
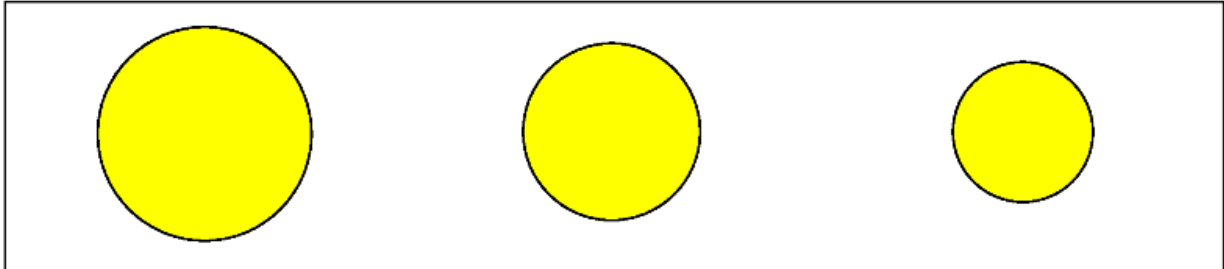





pen

pan

Circle the smallest shape in each group



Say the number aloud and colour it according to the given instructions.

- 15 -  45 -  12 -  44 -  20 -  10 -  50 -  13 - 
30 -  22 -  39 -  40 - 

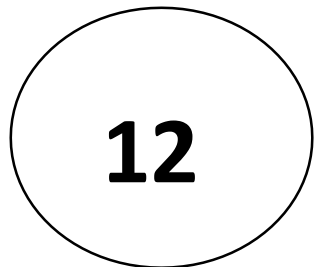
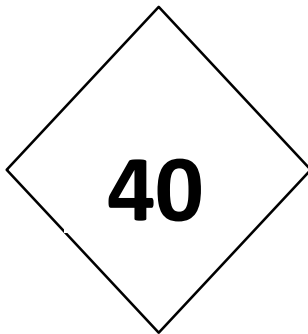
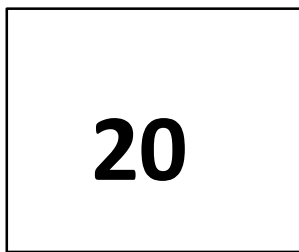
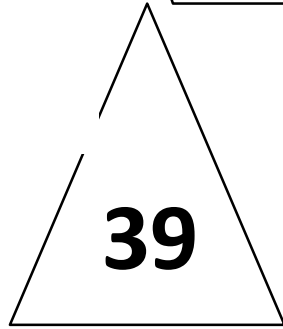
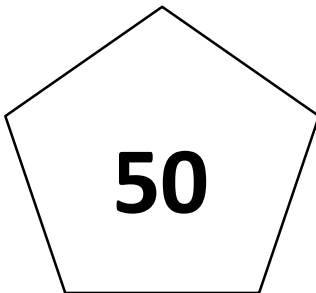
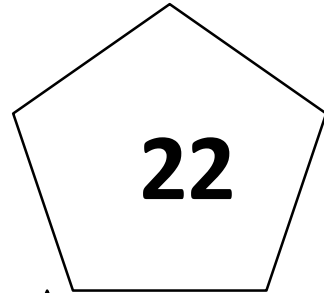
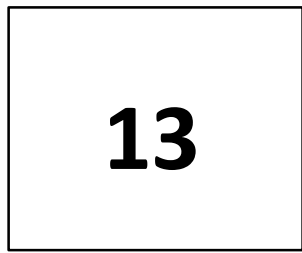
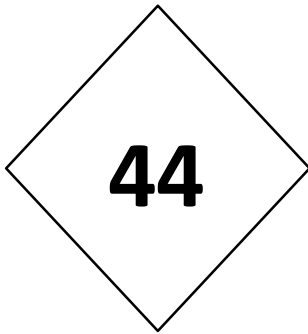
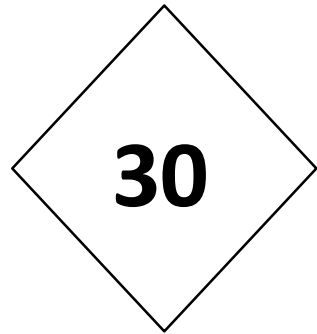
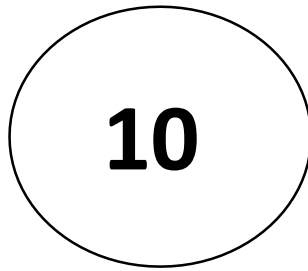
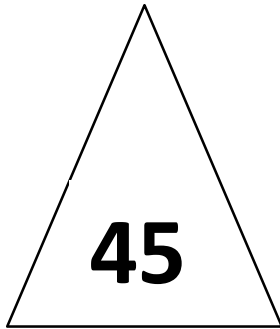
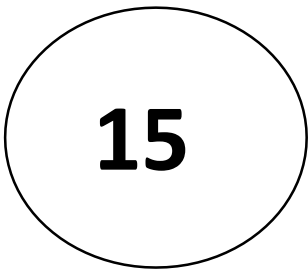



After Numbers

T O

1

T O

2 1

3 1

4 1

9

1 9

2 9

3 9

4 9

0



PAGE No _____

DATE: / /

After Numbers

T O

T O

1 0

2 0

3 0

4 0

1 3

2 7

3 6

4 8

7

1 2

After Numbers

T O

4 1

T O

3 2

2 3

1 4

4 5

3 6

2 7

1 8

4 9

3 0



PAGE No _____

DATE: / /

After Numbers

T O

T O

3

1 2

5

1 4

7

1 6

9

1 8

0

2 0

After Numbers

T O

T O

2 2

3 1

2 4

3 3

2 6

3 5

2 8

3 7

3 0

3 9

After Numbers

T 0

T 0

4 1

4 3

4 5

4 7

4 9

4 2

4 4

4 6

4 8

5 0

Between Numbers

T O
2

T O

T O
4

1 1

1 2

2 4

2 6

3 3

3 5

4 6

4 8

0

2

1 3

1 5

2 7

2 9

3 0

3 2

4 8

5 0



PAGE No _____

DATE: / /

Between Numbers.

T O

T O

T O

1

3

1 2

1 4

2 3

2 5

3 4

3 6

4 5

4 7

2 9

3 1

9

1 1

1 9

2 1

3 9

4 1

4 9

5 1



PAGE No _____

DATE: / /

Before Numbers

TO

TO

1

3

5

7

9

2

4

6

8

10

Before Numbers

TO

TO

20

18

16

14

12

19

17

15

13

11

Before Numbers

TO

TO

1 1

2

1 3

4

1 5

6

1 7

8

1 9

1 0

Before Numbers

T O

T O

3

1 2

5

1 4

7

1 6

9

1 8

1

2 0



Before Numbers

T 0

T 0

1 0

2 0

1 1

2 1

1 9

9

1

1 7

4

1 8

चित्र देखकर सही व्यंजन लिखो

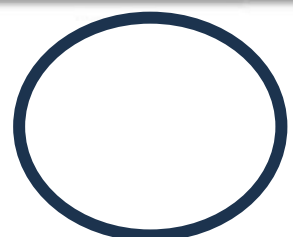
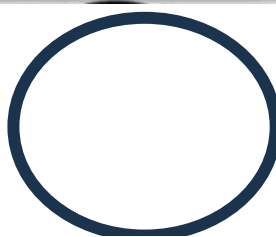
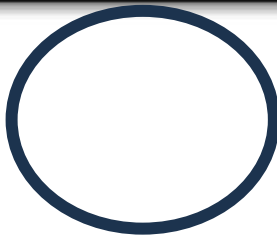
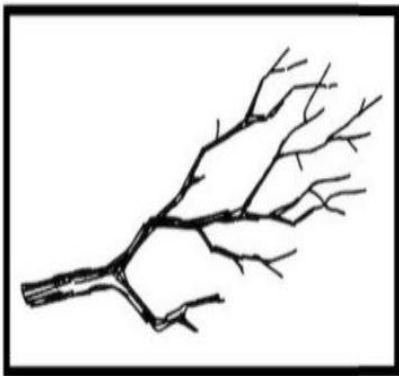
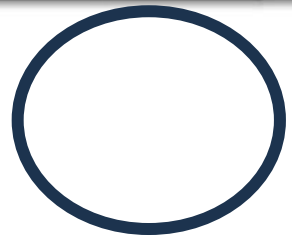
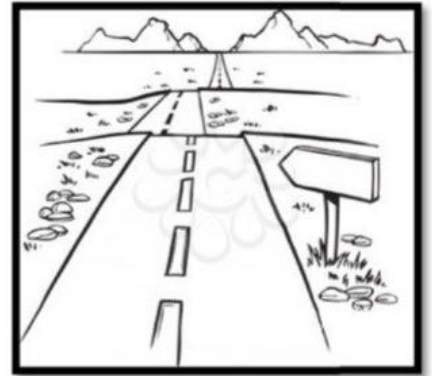
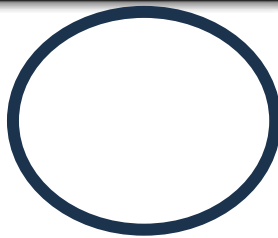
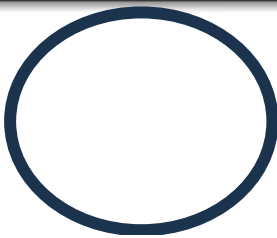
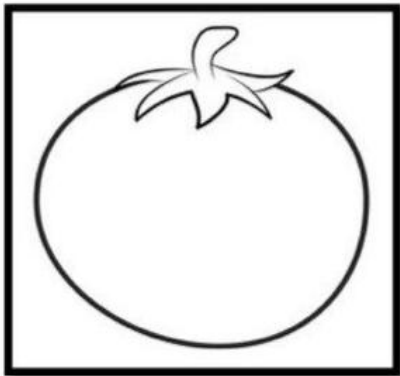

चित्र देखकर सही व्यंजन लिखो

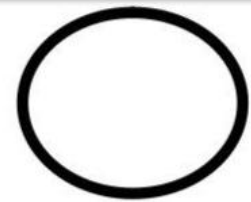
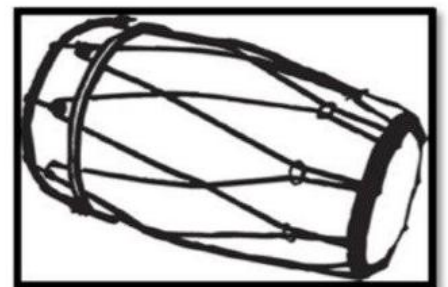
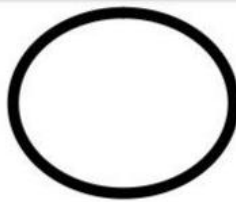
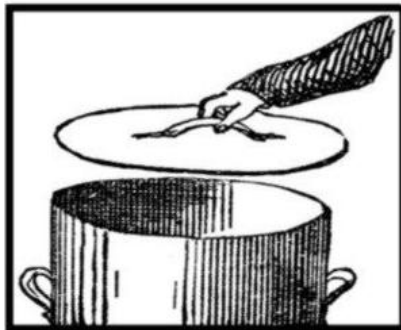
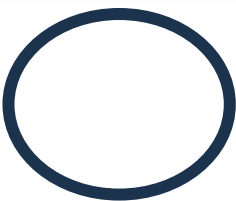
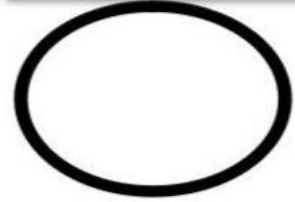
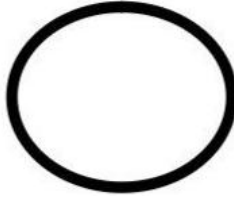
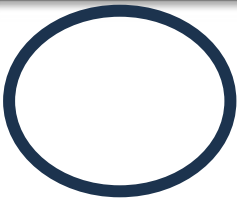
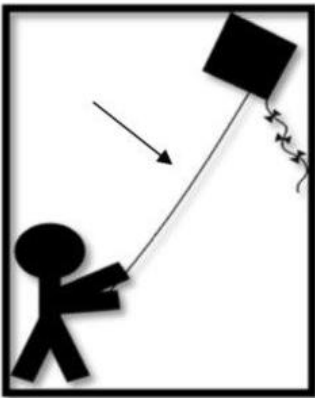
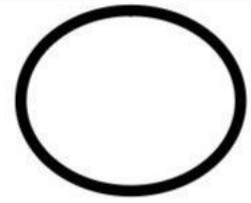
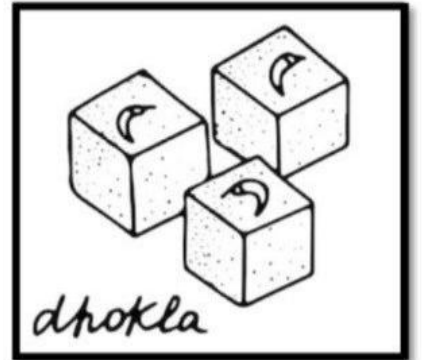
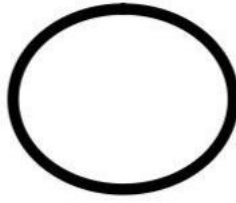
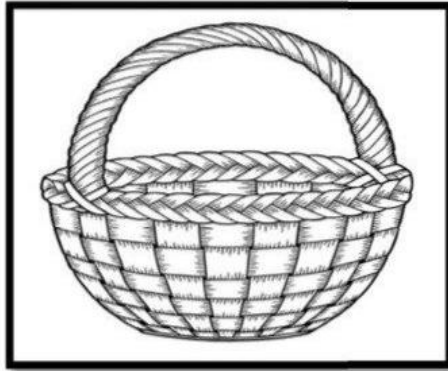
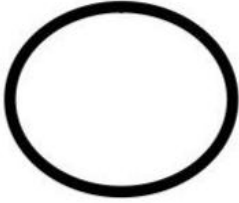
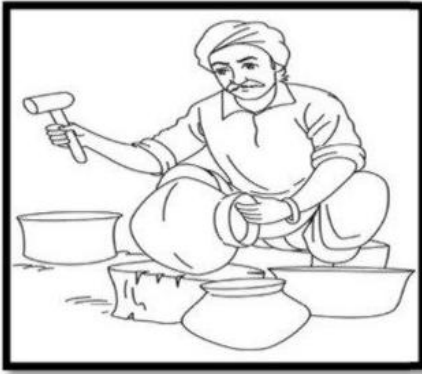

ट वर्ग व्यंजन क्रमानुसार लिखो

ट

ठ

ड

ढ

ण

